

Action

NAOS MAG

AGAINST FIXED IDEAS

Cocktail
TABLES

NAOS
THE ORIGINAL
ACTION
DESIGN

ART
of Glam
coffee
Tables



Scent of elegance

My Flower



Myflower design D. D'Urbino P. Lomazzi



TAVOLINO ESTENSIBILE CON 3 PIANI GIREVOLI SINCRORIZZATI IN CRISTALLO O CERAMICA. LA PARTICOLARE GEOMETRIA DEI PIANI E DEL MECCANISMO PERMETTE AL TAVOLO IN POSIZIONE CHIUSA DI NASCONDERE I PIANI SOTTOSTANTI. BASE E SUPPORTI IN ACCIAIO VERNICIATO O CROMATO.

EXTENSIBLE COFFEE TABLE WITH 3 SYNCHRONIZED REVOLVING TOPS IN GLASS OR CERAMIC. THE PECULIAR TOPS AND MECHANISM GEOMETRY ALLOWS THE LOWER TOPS TO BE HIDDEN IN THE CLOSED POSITION. BASE AND SUPPORTS IN PAINTED OR CHROMED STEEL.

TABLE DE SALON EXTENSIBLE AVEC 3 PLATEAUX PIVOTANTS SYNCHRONISÉS EN VERRE OU CERAMIQUE. LA GÉOMETRIE SPÉCIFIQUE DES PLATEAUX ET DU MÉCANISME, PERMET DE CACHER, EN POSITION FERMÉE, LES PLATEAUX INFÉRIEURS. SOCLE ET SUPPORTS EN ACIER LAQUE' OU CHROME'.

AUSZIEHBARER COUCHTISCH MIT 3 SYNCHRONISIERTEN DREHBAREN PLATTEN AUS KRISTALLGLAS ODER KERAMIK. DIE BESONDERE GEOMETRIE DER PLATTEN UND MECHANISMUS ERLAUBT DER COUCHTISCH IN GESCHLOSSENER POSITION DIE UNTEREN PLATTEN ZU VERSTECKEN. BASIS UND TRÄGER AUS VERCHROMTEM ODER LACKIERTEM STAHL.







The Essenzial -Chic

Madison

Madison design A. Casati



TAVOLINO ESTENSIBILE CON 4 PIANI IN CRISTALLO O CERAMICA. DOTATO DI UN INNOVATIVO DOPPIO MECCANISMO SINCRONIZZATO DI APERTURA CHE PERMETTE AI 4 CRISTALLI DI APRIRSI CON UN SOLO GESTO MA IN DIREZIONI OPPOSITE. SUPPORTI IN ACCIAIO VERNICIATO O CROMATO.

EXTENSIBLE COFFEE TABLE WITH 4 GLASS OR CERAMIC TOPS. EQUIPPED WITH AN INNOVATIVE DOUBLE SYNCHRONIZED MECHANISM THAT ALLOW THE 4 TOPS TO BE OPENED AT ONCE, WITH A SIMPLE GESTURE AND BE AT THE SAME TIME PLACED IN DIFFERENT DIRECTIONS. SUPPORTS IN PAINTED OR CHROMED STEEL.

TABLE DE SALON EXTENSIBLE AVEC 4 PLATEAUX EN VERRE OU CERAMIQUE. EQUIPEE D'UN MECANISME SYNCHRONISE A DOUBLE EFFET, QUI PERMET L'OUVERTURE SIMULTANEE DES 4 PLATEAUX, MAIS EN DIRECTIONS OPPOSEES. SUPPORTS EN ACIER LAQUE OU CHROME.

AUSZIEHBARER COUCHTISCH MIT 4 PLATTEN AUS KRISTALLGLAS ODER KERAMIK. AUSGESTATTET MIT EINER INNOVATIVEN SYNCHRONISIERTEN DOPPELMECHANISMUS, DIE MIT EINER EINZIGEN BEWEGUNG DIE 4 GLASPLATTEN ERLAUBT SICH ZU OEFFNEN, ABER IN GEGENSAETZLICHEN RICHTUNGEN. TRAEGER AUS VERCHROMTEM ODER LACKIERTEM STAHL.





Batis design A. Casati



TAVOLINO ESTENSIBILE CON 3 PIANI IN CRISTALLO O CERAMICA. DOTATO DI UN INNOVATIVO DOPPIO MECCANISMO SINCRONIZZATO DI APERTURA CHE PERMETTE AI 3 CRISTALLI DI APRIRSI CON UN SOLO GESTO MA IN DIREZIONI OPPOSTE. SUPPORTI IN ACCIAIO VERNICIATO O CROMATO.

EXTENSIBLE COFFEE TABLE WITH 3 GLASS OR CERAMIC TOPS. EQUIPPED WITH AN INNOVATIVE DOUBLE SYNCHRONIZED MECHANISM THAT ALLOW THE 3 TOPS TO BE OPENED AT ONCE, WITH A SIMPLE GESTURE AND BE AT THE SAME TIME PLACED IN DIFFERENT DIRECTIONS. SUPPORTS IN PAINTED OR CHROMED STEEL.

TABLE DE SALON EXTENSIBLE AVEC 3 PLATEAUX EN VERRE OU CERAMIQUE. EQUIPÉE D'UN MÉCANISME SYNCHRONISÉ À DOUBLE EFFET, QUI PERMET L'OUVERTURE SIMULTANÉE DES 3 PLATEAUX, MAIS EN DIRECTIONS OPPOSÉES. SUPPORTS EN ACIER LAQUÉ OU CHROMÉ.

AUSZIEHBARER COUCHTISCH MIT 3 PLATTEN AUS KRISTALLGLAS ODER KERAMIK. AUSGESTATTET MIT EINER INNOVATIVEN SYNCHRONISIERTEN DOPPELMECHANISMUS, DIE MIT EINER EINZIGEN BEWEGUNG DIE 3 GLASPLATTEN ERLAUBT SICH ZU ÖFFNEN, ABER IN GEGENSÄTZLICHEN RICHTUNGEN. TRÄGER AUS VERCHROMTEM ODER LACKIERTEM STAHL.



The Beauty of Crystal Geometry

Calypso



Calypso design Y. Hatano

TAVOLINO ESTENSIBILE CON
PIANI GIREVOLI SINCRONIZZATI
IN CRISTALLO. BASE E SUPPORTI
IN ACCIAIO VERNICIATO O
GALVANIZZATO. DISPONIBILE ANCHE
CON BASE IN CERAMICA, CRISTALLO
VERNICIATO O SPECCHIO.
PIANI DISPONIBILI IN CERAMICA O IL
SOLO PIANO SUPERIORE IN ROVERE.

EXTENSIBLE COCKTAIL TABLE WITH
SYNCHRONISED REVOLVING GLASS
TOPS. BASE AND SUPPORTS IN
GALVANISED OR PAINTED STEEL.
AVAILABE ALSO WITH CERAMICS,
PAINTED GLASS OR MIRROR BASE.
AVAILABLE CERAMICS TOPS AND
ONLY BIG TOP IN OAK.

TABLE DE SALON EXTENSIBLE
AVEC PLATEAUX TOURNANTS-
SYNCHRONISÉS EN VERRE. BASE
ET SUPPORTS EN ACIER LAQUÉ OU
GALVANISÉ. DISPONIBILE AUSSI AVEC
SOCLE EN CERAMIQUE, EN VERRE
LAQUE' OU EN MIRROIR. PLATEAUX
DISPONIBLES EN CERAMIQUE OU
SEULEMENT PLATEAU SUPERIEUR EN
CHENE.

AUSZIEHBARER COUCHTISCH
MIT SYNCHRON DREHBAREN
KRISTALLGLASPLATTEN. BASIS UND
TRÄGER AUS LACKIERTEM ODER
GALVANISIERTEM STAHL. LIEFERBAR
AUCH MIT BASIS AUS KERAMIK,
LACKERTEM GLASS ODER SPIEGEL.
PLATTEN AUS KERAMIK ODER MIT
NUR OBERE PLATTE AUS EICHE.

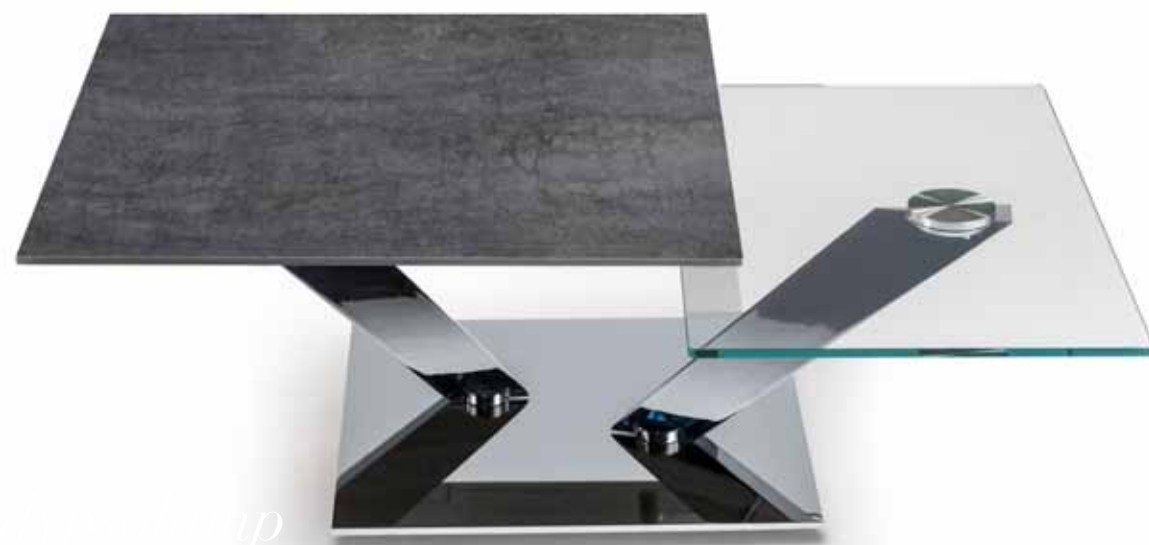

Cassius design A. Gamba L. Guerra

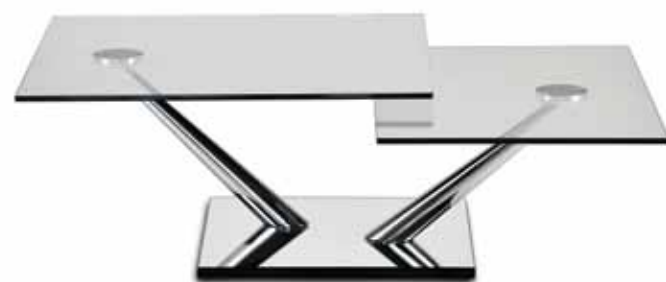

TAVOLINO ESTENSIBILE CON PIANI GIREVOLI SINCRONIZZATI IN CRISTALLO. BASE E SUPPORTI IN ACCIAIO VERNICIATO O GALVANIZZATO. DISPONIBILE ANCHE CON BASE IN CERAMICA, CRISTALLO VERNICIATO O SPECCHIO. PIANI DISPONIBILI IN CERAMICA O IL SOLO PIANO SUPERIORE IN ROVERE.

EXTENSIBLE COCKTAIL TABLE WITH SYNCHRONISED REVOLVING GLASS TOPS. BASE AND SUPPORTS IN GALVANISED OR PAINTED STEEL. AVAILABE ALSO WITH CERAMICS, PAINTED GLASS OR MIRROR BASE. AVAILABLE CERAMICS TOPS AND ONLY BIG TOP IN OAK.

TABLE DE SALON EXTENSIBLE AVEC PATEAUX TOURNANTS-SYNCHRONISÉS EN VERRE. BASE ET SUPPORTS EN ACIER LAQUÉ OU GALVANISÉ. DISPONIBILE AUSSI AVEC SOCLE EN CERAMIQUE, EN VERRE LAQUE' OU EN MIRROIR. PATEAUX DISPONIBLES EN CERAMIQUE OU SEULEMENT PATEAU SUPERIEUR EN CHENE.

AUSZIEHBARER COUCHTISCH MIT SYNCHRON DREHBAREN KRISTALLGLASPLATTEN. BASIS UND TRÄGER AUS LACKIERTEM ODER GALVANISIERTEM STAHL. LIEFERBAR AUCH MIT BASIS AUS KERAMIK, LACKERTEM GLASS ODER SPIEGEL. PLATTEN AUS KERAMIK ODER MIT NUR OBERE PLATTE AUS EICHE.

Abra design A. Gamba L. Guerra

TAVOLINO ESTENSIBILE CON PIANI GIREVOLI SINCRONIZZATI IN CRISTALLO. BASE E SUPPORTI IN ACCIAIO VERNICIATO O GALVANIZZATO. LA BASE E' DOTATA DI UN MECCANISMO PER LA ROTAZIONE SINCRONIZZATA, CHE CONSENTE UN'AMPIA MODULAZIONE DELLA FORMA. DISPONIBILE ANCHE CON PIANI IN CERAMICA.

EXTENDIBLE COFFEE TABLE WITH SYNCHRONIZED REVOLVING CRYSTAL TOPS. BASE AND SUPPORTS IN PAINTED OR GALVANIZED STEEL. THE BASE IS EQUIPPED WITH A MECHANISM FOR THE SYNCHRONIZED ROTATION OF THE TOPS THAT ALLOWS AMPLE MODULATION OF THE FORM. AVAILABE ALSO WITH CERAMICS TOPS.

TABLE DE SALON EXTENSIBLE AVEC PLATEAUX TOURNANTS- SYNCHRONISÉS EN VERRE. PIÉTEMENT ET SUPPORTS EN ACIER LAQUÉ OU GALVANISÉ. LA BASE EST ÉQUIPÉE D'UN MÉCANISME DE ROTATION SYNCHRONISÉE QUI PERMET UNE AMPLE MODULATION DE LA FORME. DISPONIBILE AUSSI AVEC PLATEAUX EN CERAMIQUE.

AUSZIEHBARER COUCHTISCH MIT SYNCHRON DREHBAREN KRISTALLGLASPLATTEN. BASIS UND TRÄGER AUS LACKIERTEM ODER GALVANISIERTEM STAHL. DER BESONDERE MECHANISMUS ERLAUBT ES DEN PLATTEN VIELFÄLTIGE POSITIONEN EINZUNEHMEN. LIEFERBAR AUCH MIT KERAMIKPLATTEN.





Cadabra design A. Gamba L. Guerra



TAVOLINO ESTENSIBILE CON PIANI GIREVOLI
SINCRONIZZATI IN CRISTALLO. SUPPORTI IN ACCIAIO
VERNICIATO O GALVANIZZATO. DISPONIBILE CON
BASE IN CERAMICA, CRISTALLO VERNICIATO O
SPECCHIO. PIANI DISPONIBILI IN CERAMICA O IL
SOLO PIANO SUPERIORE IN ROVERE.

EXTENSIBLE COCKTAIL TABLE WITH SYNCHRONISED
REVOLVING GLASS TOPS. SUPPORTS IN GALVANISED
OR PAINTED STEEL. AVAILABE WITH CERAMICS,
PAINTED GLASS OR MIRROR BASE. AVAILBLE
CERAMICS TOPS AND ONLY BIG TOP IN OAK.

TABLE DE SALON EXTENSIBLE AVEC PLATEAUX
TOURNANTS-SYNCHRONISÉS EN VERRE. SUPPORTS
EN ACIER LAQUÉ OU GALVANISÉ. DISPONIBILE AVEC
SOCLE EN CERAMIQUE, EN VERRE LAQUE' OU EN
MIRROIR. PLATEAUX DISPONIBLES EN CERAMIQUE OU
SEULEMENT PLATEAU SUPERIEUR EN CHENE.

AUSZIEHBARER COUCHTISCH MIT SYNCHRON
DREHBAREN KRISTALLGLASPLATTEN. TRÄGER
AUS LACKIERTEM ODER GALVANISIERTEM STAHL.
LIEFERBAR MIT BASIS AUS KERAMIK, LACKERTEM
GLASS ODER SPIEGEL. PLATTEN AUS KERAMIK ODER
MIT NUR OBERE PLATTE AUS EICHE.

Extremis design A. Casati



TAVOLINO ESTENSIBILE CON 3 PIANI IN CERAMICA. DOTATO DI UN INNOVATIVO MECCANISMO SINCRONIZZATO DI APERTURA CHE PERMETTE AI 3 CRISTALLI DI APRIRSI CON UN SOLO GESTO. SUPPORTI IN ACCIAIO VERNICIATO.

EXTENSIBLE COFFEE TABLE WITH 3 CERAMIC TOPS. EQUIPPED WITH AN INNOVATIVE SYNCHRONIZED MECHANISM THAT ALLOW THE 3 TOPS TO BE OPENED AT ONCE, WITH A SIMPLE GESTURE AND BE AT THE SAME TIME PLACED IN DIFFERENT DIRECTIONS. SUPPORTS IN PAINTED STEEL.

TABLE DE SALON EXTENSIBLE AVEC 3 PLATEAUX EN CERAMIQUE. EQUIPÉE D'UN MÉCANISME SYNCHRONISÉ QUI PERMET L'OUVERTURE SIMULTANÉE DES 3 PLATEAUX, SUPPORTS EN ACIER LAQUÉ.

AUSZIEHBARER COUCHTISCH MIT 3 PLATTEN AUS KERAMIK. AUSGESTATTET MIT EINER INNOVATIVEN SYNCHRONISIERTEN MECHANISMUS, DIE MIT EINER EINZIGEN BEWEGUNG DIE 3 GLASPLATTEN ERLAUBT SICH ZU ÖFFNEN, TRÄGER AUS LACKIERTEM STAHL.



Flag design D. D'Urbino



TAVOLINO ESTENSIBILE CON PIANI IN CERAMICA, BASE IN CRISTALLO. DOTATO DI UN INNOVATIVO MECCANISMO CHE, ATTRAVERSO LA SOLA ROTAZIONE DEL PIANO, PERMETTE AI DUE PIANETTI DI APRIRSI.

EXTENSIBLE COCKTAIL TABLE WITH CERAMIC, GLASS BASE. EQUIPPED WITH AN INNOVATIVE MECHANISM THAT THROUGH THE TOP ROTATION, ALLOWS THE 2 SMALL TOPS TO OPEN AUTOMATICALLY.

TABLE DE SALON AVEC PLATEAUX EN CERAMIQUE, BASE EN VERRE, EQUIPEE D'UN MECANISME NOVATEUR QUI, PAR LA SEULE ROTATION DU PLATEAU PERMET L'OUVERTURE DES 2 TABLETTES.

AUSZIEHBARER COUCHTISCH MIT KERAMIKPLATTEN. BASIS AUS KRISTALLGLAS. AUSGESTATTET MIT EINEM INNOVATIVEN MECHANISMUS, DIE DURCH EINE DREHUNG DER PLATTE ES ERMÖGLICHT DIE 2 REGALE ZU ÖFFNEN.



Riviera design A. Casati



TAVOLINO ESTENSIBILE CON PIANI IN CERAMICA E CRISTALLO, BASE IN CERAMICA. DOTATO DI UN INNOVATIVO MECCANISMO CHE, ATTRAVERSO LA SOLA ROTAZIONE DEL PIANO SUPERIORE, PERMETTE AI DUE PIANETTI SOTTOSTANTI DI APRIRSI.

EXTENSIBLE COCKTAIL TABLE WITH CERAMIC AND GLASS TOPS, CERAMIC BASE. EQUIPPED WITH AN INNOVATIVE MECHANISM THAT THROUGH THE UPPER ROUND TOP ROTATION, ALLOWS THE LOWEST 2 SMALL TOPS TO OPEN AUTOMATICALLY.

TABLE DE SALON AVEC PLATEAUX EN CERAMIQUE ET VERRE, BASE EN CERAMIQUE, EQUIPEE D'UN MECANISME NOVATEUR QUI, PAR LA SEULE ROTATION DU PLATEAU SUPERIEUR PERMET L'OUVERTURE DES 2 TABLETTES INFERIEURES.

AUSZIEHBARER COUCHTISCH MIT KERAMIKPLATTEN UND KRISTALLGLAS. BASIS AUS KERAMIK. AUSGESTATTET MIT EINEM INNOVATIVEN MECHANISMUS, DIE DURCH EINE DREHUNG DER OBERPLATTE ES ERMÖGLICHT DIE 2 UNTERE REGALE ZU ÖFFNEN.



Uptown



Uptown design A. Casati

TAVOLINO ESTENSIBILE CON PIANI IN CERAMICA E CRISTALLO, BASE IN ACCIAIO VERNICIATO O GALVANIZZATO. DOTATO DI UN INNOVATIVO MECCANISMO CHE, ATTRAVERSO LA SOLA ROTAZIONE DEL PIANO SUPERIORE, PERMETTE AI DUE PIANETTI SOTTOSTANTI DI APRIRSI. DISPONIBILE ANCHE SENZA MECCANISMO.

EXTENSIBLE COCKTAIL TABLE WITH CERAMIC AND GLASS TOPS, PAINTED OR GALVANIZED STEEL BASE. EQUIPPED WITH AN INNOVATIVE MECHANISM THAT THROUGH THE UPPER ROUND TOP ROTATION, ALLOWS THE LOWEST 2 SMALL TOPS TO OPEN AUTOMATICALLY. AVAILABLE ALSO WITHOUT MECHANISM.

TABLE DE SALON AVEC PLATEAUX EN CERAMIQUE ET VERRE, BASE EN ACIER LAQUEE OU TRAITEE AU BAIN GALVANIQUE, EQUIPEE D'UN MECANISME NOVATEUR QUI, PAR LA SEULE ROTATION DU PLATEAU SUPERIEUR PERMET L'OUVERTURE DES 2 TABLETTES INFERIEURES. DISPONIBLE AUSSI SANS MECANISME.

AUSZIEHBARER COUCHTISCH MIT KERAMIKPLATTEN UND KRISTALLGLAS. BASIS AUS LACKIERTEM ODER GALVANISIERTEM STAHL. AUSGESTATTET MIT EINEM INNOVATIVEN MECHANISMUS, DIE DURCH EINE DREHUNG DER OBENPLATTE ES ERMÖGLICHT DIE 2 UNTERE REGALE ZU ÖFFNEN. VERFÜGBAR AUCH IN DER FEST VERSION.



The rare simplicity of a gesture

Hive



Hive design A. Casati

TAVOLINO ESTENSIBILE CON PIANI IN CERAMICA E CRISTALLO, BASE IN ACCIAIO VERNICIATO O GALVANIZZATO. DOTATO DI UN INNOVATIVO MECCANISMO CHE, ATTRAVERSO LA SOLA ROTAZIONE DEL PIANO SUPERIORE, PERMETTE AI TRE PIANETTI SOTTOSTANTI DI APRIRSI. DISPONIBILE ANCHE SENZA MECCANISMO.

EXTENSIBLE COCKTAIL TABLE WITH CERAMIC AND GLASS TOPS, PAINTED OR GALVANIZED STEEL BASE. EQUIPPED WITH AN INNOVATIVE MECHANISM THAT THROUGH THE UPPER ROUND TOP ROTATION, ALLOWS THE LOWEST 3 SMALL TOPS TO OPEN AUTOMATICALLY. AVAILABLE ALSO WITHOUT MECHANISM.

TABLE DE SALON AVEC PLATEAUX EN CERAMIQUE ET VERRE, BASE EN ACIER. LAQUEE OU TRAITEE AU BAIN GALVANIQUE, EQUIPEE D'UN MECANISME NOVATEUR QUI, PAR LA SEULE ROTATION DU PLATEAU SUPERIEUR PERMET L'OUVERTURE DES 3 TABLETTES INFERIEURES. DISPONIBLE AUSSI SANS MECANISME.

AUSZIEHBARER COUCHTISCH MIT KERAMIKPLATTEN UND KRISTALLGLAS. BASIS AUS LACKIERTEM ODER GALVANISIERTEM STAHL. AUSGESTATTET MIT EINEM INNOVATIVEN MECHANISMUS, DIE DURCH EINE DREHUNG DER OBERPLATTE ES ERMÖGLICHT DIE 3 UNTERE REGALE ZU ÖFFNEN. VERFÜGBAR AUCH IN DER FEST VERSION.



lamp



dessert



Les Jeux Sont Faits

An Unpredictable Play



Les Jeux Sont Faits *design A. Casati*

TAVOLINO ESTENSIBILE CON PIANI IN CERAMICA E CRISTALLO, BASE IN ACCIAIO VERNICIATO O GALVANIZZATO. DOTATO DI UN INNOVATIVO MECCANISMO CHE, ATTRAVERSO LA SOLA ROTAZIONE DEL PIANO SUPERIORE, PERMETTE AI TRE PIANETTI SOTTOSTANTI DI APRIRSI. DISPONIBILE ANCHE SENZA MECCANISMO.

EXTENSIBLE COCKTAIL TABLE WITH CERAMIC AND GLASS TOPS, PAINTED OR GALVANIZED STEEL BASE. EQUIPPED WITH AN INNOVATIVE MECHANISM THAT THROUGH THE UPPER ROUND TOP ROTATION, ALLOWS THE LOWEST 3 SMALL TOPS TO OPEN AUTOMATICALLY. AVAILABLE ALSO WITHOUT MECHANISM.

TABLE DE SALON AVEC PLATEAUX EN CERAMIQUE ET VERRE, BASE EN ACIER. LAQUEE OU TRAITEE AU BAIN GALVANIQUE, EQUIPEE D'UN MECANISME NOVATEUR QUI, PAR LA SEULE ROTATION DU PLATEAU SUPERIEUR PERMET L'OUVERTURE DES 3 TABLETTES INFERIEURES. DISPONIBLE AUSSI SANS MECANISME.

AUSZIEHBARER COUCHTISCH MIT KERAMIKPLATTEN UND KRISTALLGLAS. BASIS AUS LACKIERTEM ODER GALVANISIERTEM STAHL. AUSGESTATTET MIT EINEM INNOVATIVEN MECHANISMUS, DIE DURCH EINE DREHUNG DER OBERPLATTE ES ERMÖGLICHT DIE 3 UNTERE REGALE ZU ÖFFNEN. VERFÜGBAR AUCH IN DER FEST VERSION.

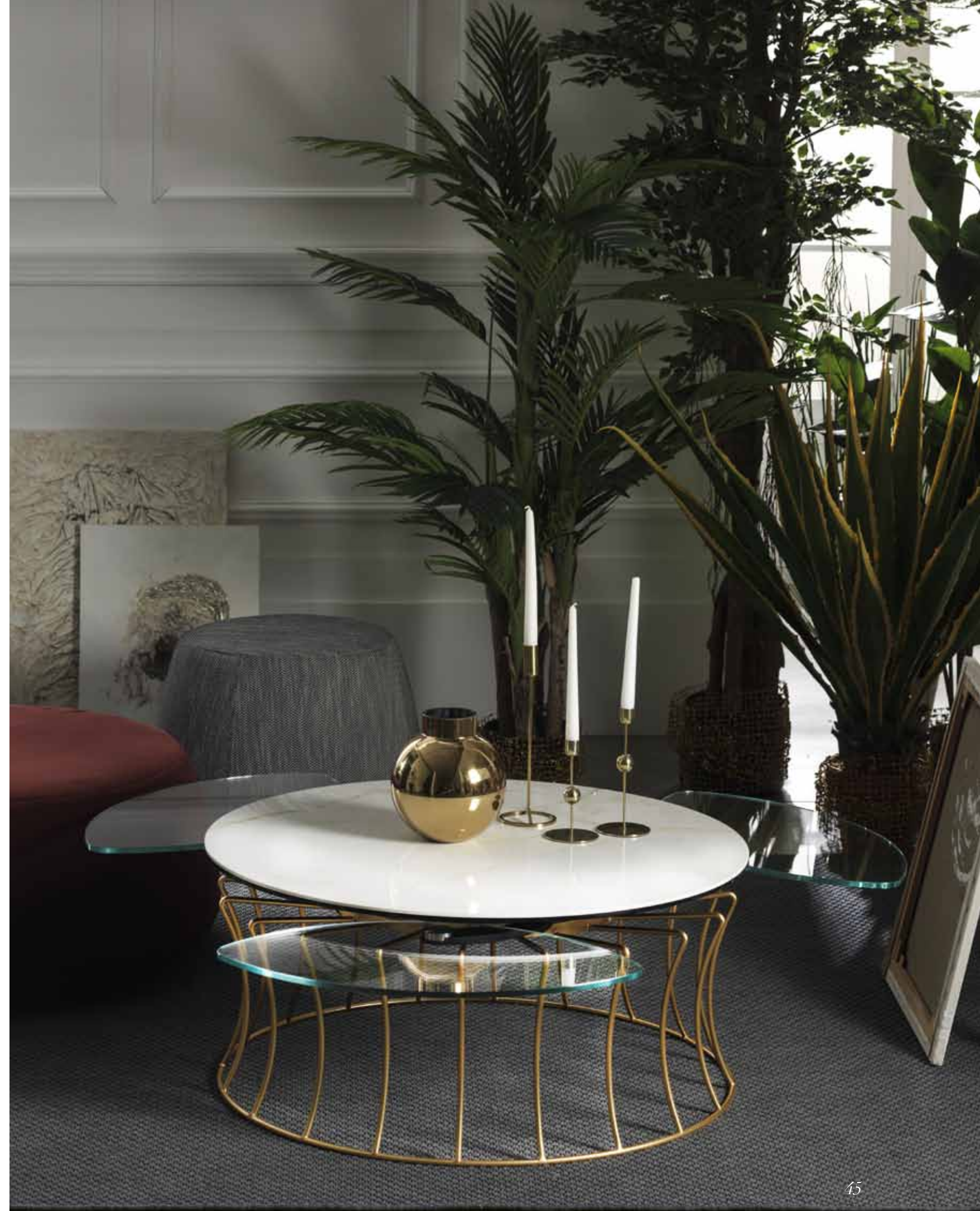

Matching Corner Tables

Calypsolamp



TAVOLINO COORDINATO NELLE STESSE FINITURE.
LAMP TABLE IN MATCHING FINISH RANGE.
BOUT DE CANAPÉ EN CORDONNE.
PASSENDER BEISTELLTISCH IN GLEICHEN
AUSFÜHRUNGEN.

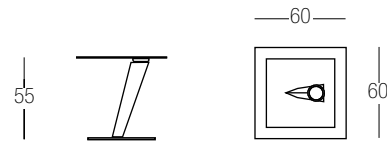

Harry



TAVOLINO COORDINATO NELLE STESSE FINITURE.
LAMP TABLE IN MATCHING FINISH RANGE.
BOUT DE CANAPÉ EN CORDONNE.
PASSENDER BEISTELLTISCH IN GLEICHEN
AUSFÜHRUNGEN.

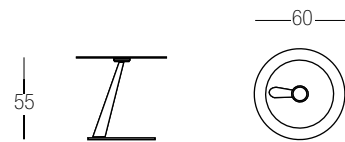

Clay



TAVOLINO COORDINATO NELLE STESSE FINITURE.
LAMP TABLE IN MATCHING FINISH RANGE.
BOUT DE CANAPÉ EN CORDONNE.
PASSENDER BEISTELLTISCH IN GLEICHEN
AUSFÜHRUNGEN.

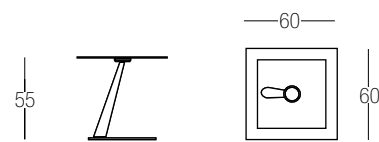

Lyps



TAVOLINO COORDINATO NELLE STESSE FINITURE.
LAMP TABLE IN MATCHING FINISH RANGE.
BOUT DE CANAPÉ EN CORDONNE.
PASSENDER BEISTELLTISCH IN GLEICHEN
AUSFÜHRUNGEN.

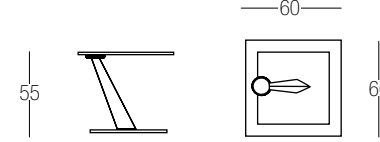

Rivieralamp



TAVOLINO COORDINATO NELLE STESSE FINITURE.
LAMP TABLE IN MATCHING FINISH RANGE.
BOUT DE CANAPÉ EN CORDONNE.
PASSENDER BEISTELLTISCH IN GLEICHEN
AUSFÜHRUNGEN.

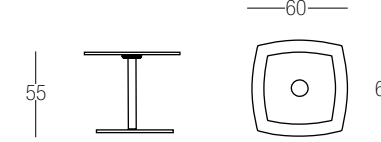

Gemellino



TAVOLINO COORDINATO NELLE STESSE FINITURE.
LAMP TABLE IN MATCHING FINISH RANGE.
BOUT DE CANAPÉ EN CORDONNE.
PASSENDER BEISTELLTISCH IN GLEICHEN
AUSFÜHRUNGEN.

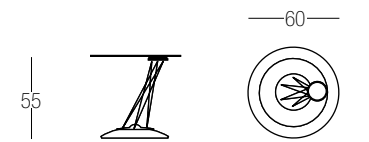

Calypso



Abra



Cassius



Aquilyps



Riviera



Gemelli



Cadabra



Aquì



03 - *My Flower*
design D.D'Urbino P.Lomazzi

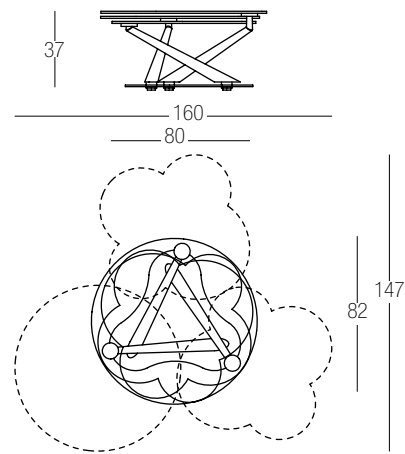

17 - *Calypso*
design Y. Hatano

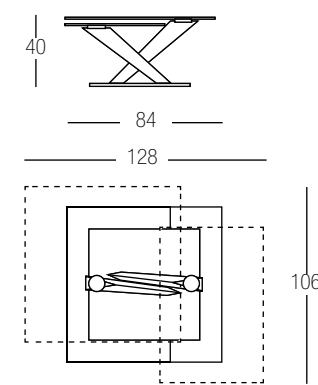

09 - *Madison*
design A. Casati

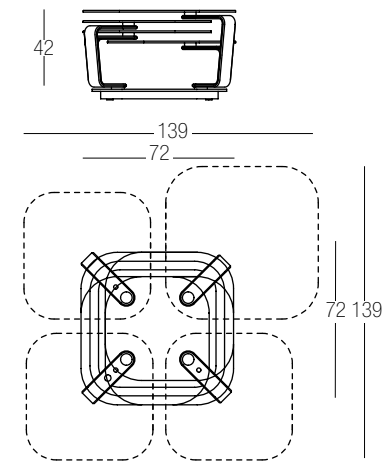

21 - *Cassius*
design A. Gamba L. Guerra

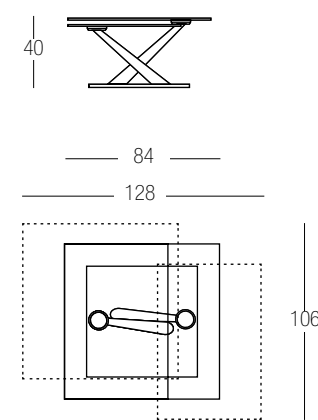

15 - *Batis*
design A. Casati

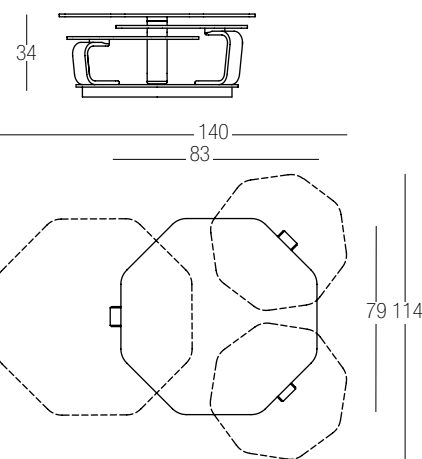

23 - *Abra / Cadabra*
design A. Gamba L. Guerra

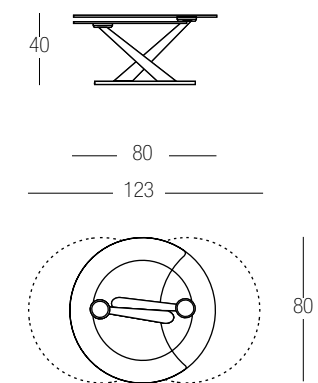

29z - *Extremis*
design A. Casati

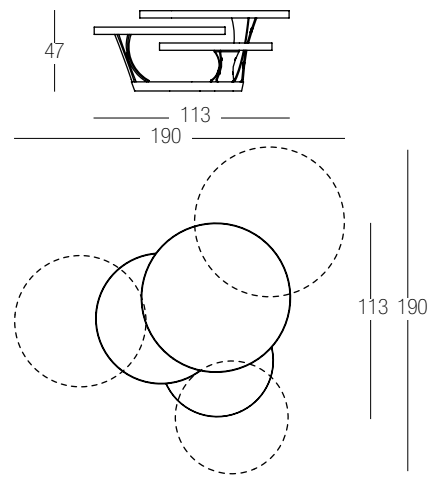

35 - *Uptown*
design A. Casati

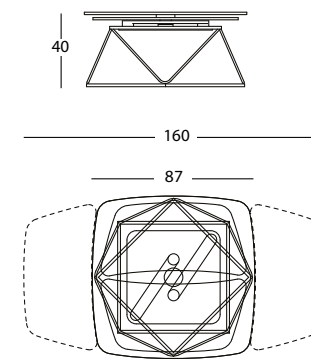

31 - *Flag*
design D. D'Urbino

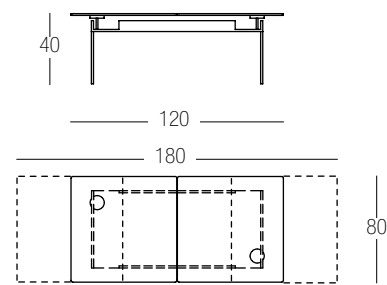

39 - *Hive*
design A. Casati

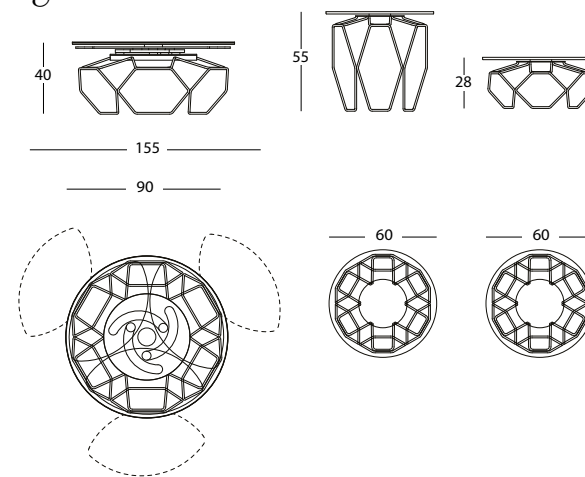

33 - *Riviera*
design A. Casati

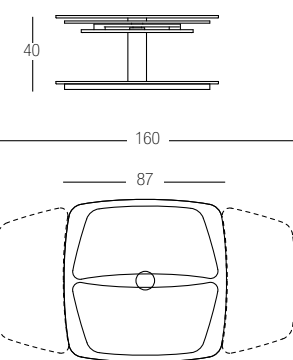

43 - *Les Jeux Sont Ffaits*
design A. Casati

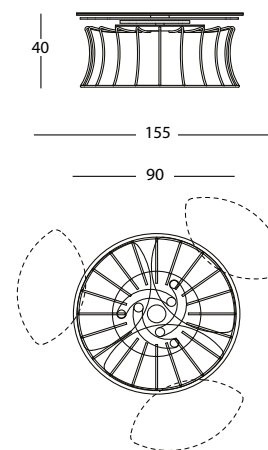

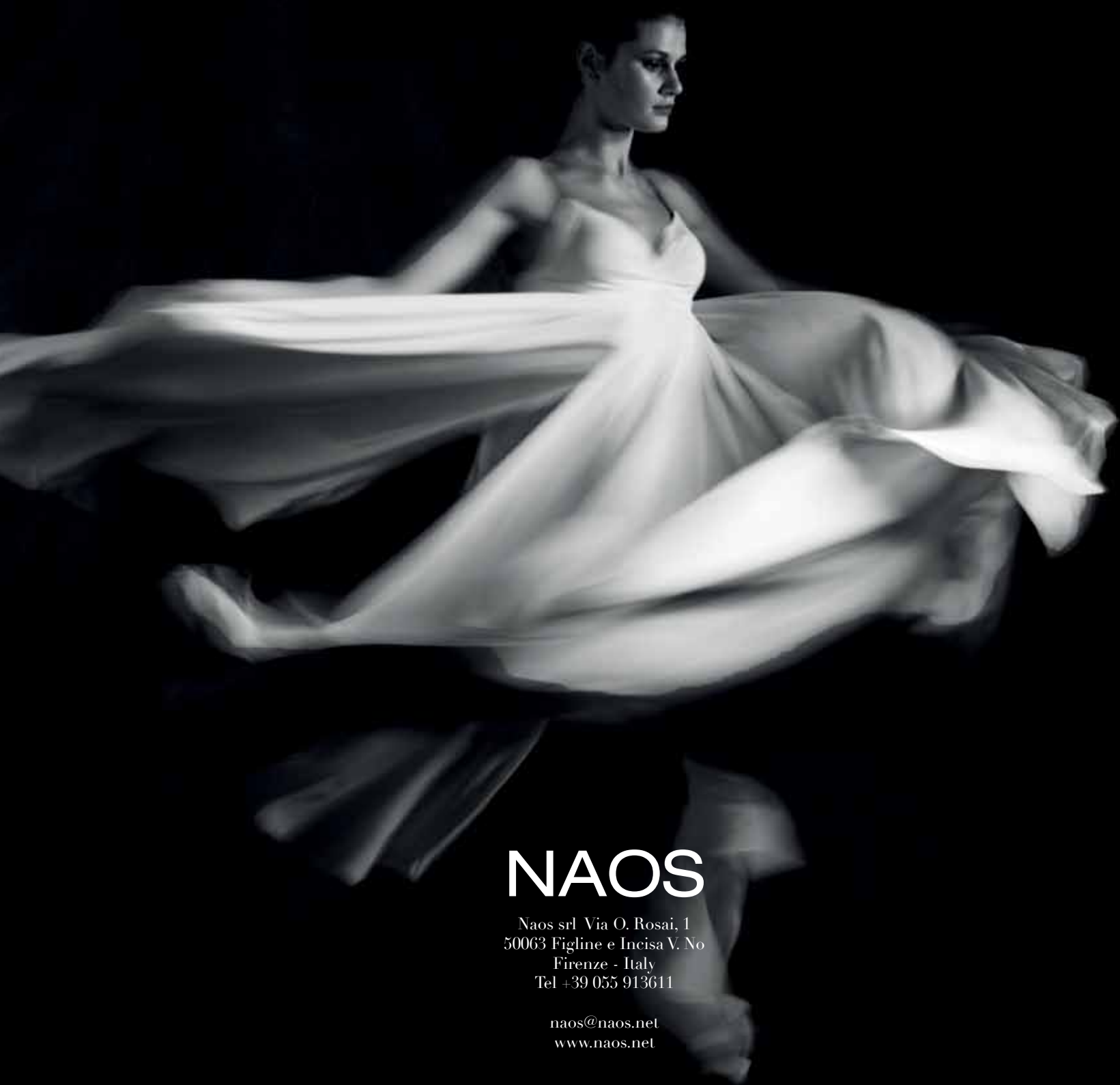

NAOS

Naos srl Via O. Rosai, 1
50063 Figline e Incisa V. No
Firenze - Italy
Tel +39 055 913611

naos@naos.net
www.naos.net



NAOS
AGAINST FIXED IDEAS

